



**ACO. creating
the future of drainage**

ACO SELF Range

Residential drainage that meet global standards



ACO Self channel and grating - Euroline 100

Domestic and residential water drainage system

If rain water is not properly diverted, it can cause structural damage inside and outside the residence. With the ACO Self® system, ACO provides drainage channels for all types of terrain and the most varied requirements.

The ACO Self® modular system offer more than a drainage function, combining functionality with the highest level of design. ONE channel For any requirement, with a range of grating designs to suit the design need.



Why choose the ACO Self channel and grating ?

➤ Modular channel system - ONE CHANNEL for any application

The ACO Self® drainage was specifically developed for private applications and combines best quality with high level of design. Some gratings are car drivable and suitable for all drainage applications around the house



Pools and water features

Terraces and decks

House entrances

Garage entrances

Driveways

Polymeric channel benefit

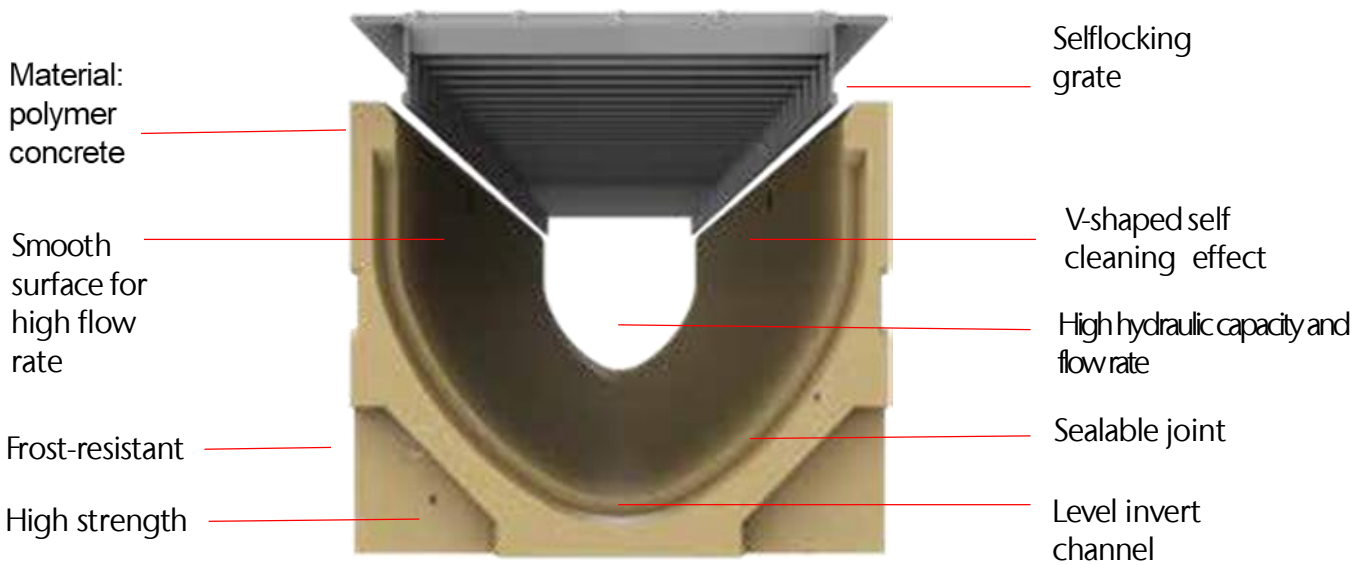

Suitable for light traffic applications up to 250kN

Euroline - one channel + different gratings

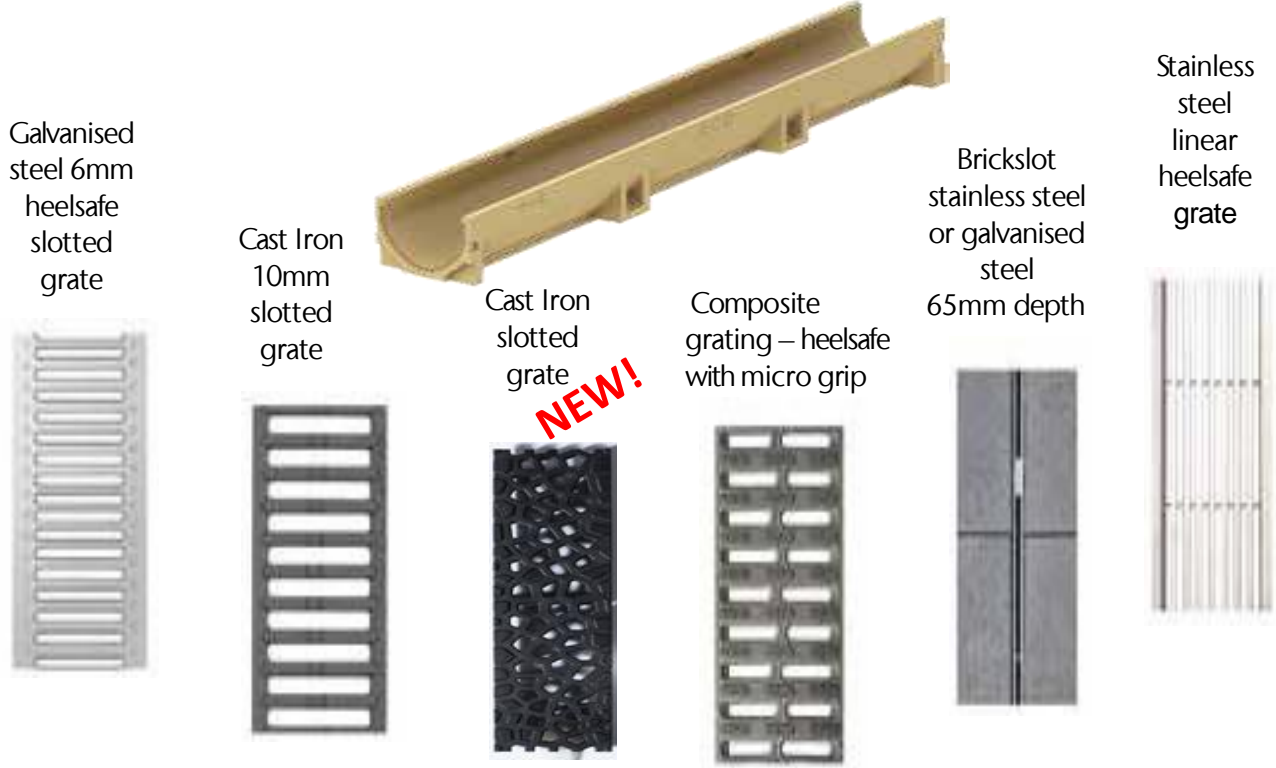

= select your perfect solution



System overview

Connection:

Type 1 Connecting to the drainage system through a sump unit, including a sludge collection bucket and optional foul air trap

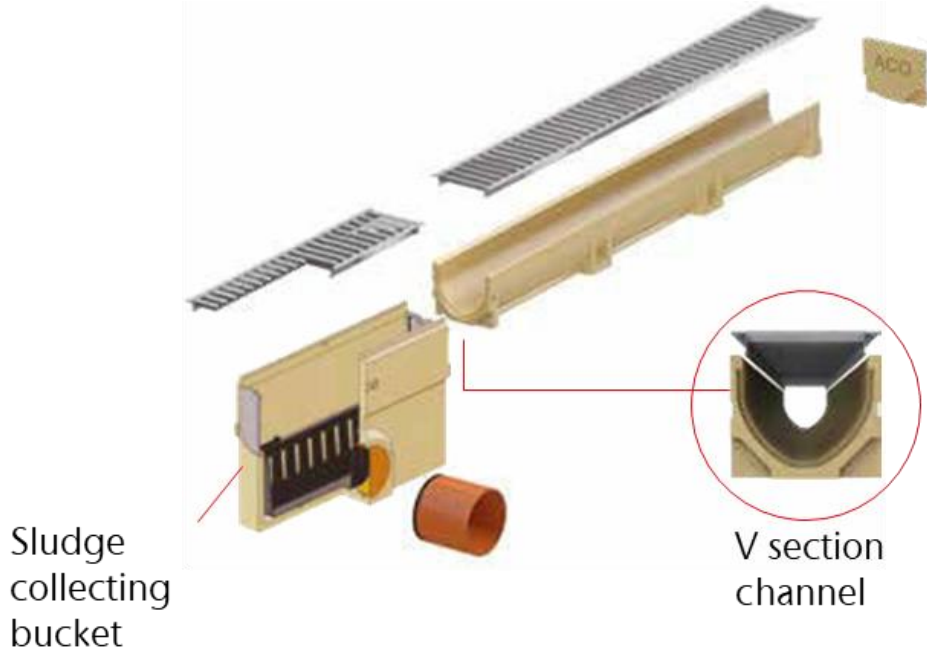

Connection:

Type 2 Connecting to the drainage system through the polymeric end cap with DN 60/100 outlet pipe fitting.

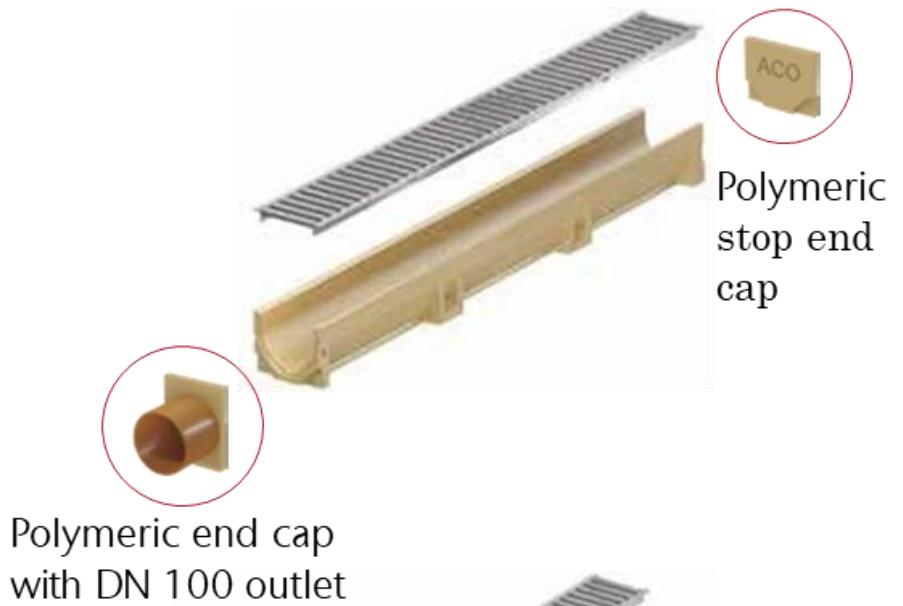

Connection:

Type 3 Connecting to the drainage system through the preform channel DN 100 knockout

Polymeric channel with preform knockout for vertical outlet application

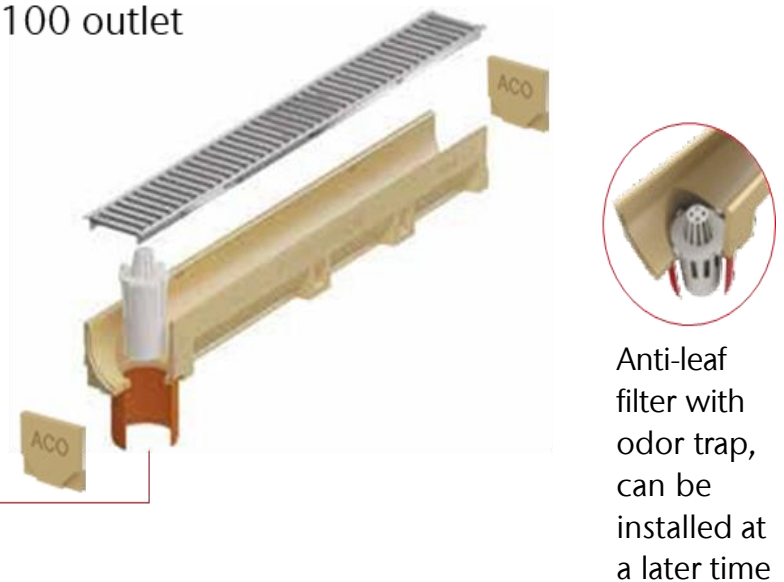

ACO SELF® product overview

Euroline 100 channel body with preform DN100 knockout



	Length (mm)	Overall Width (mm)	Depth (mm)	Weight (kg/pc)	Code
	1000	118	55	5.20	810020

Image	Description	Length (mm)	Overall Width (mm)	Depth (mm)	Weight (kg/pc)	Code
	Euroline 55 combined end cap	-	-	55	0.35	810200
	Euroline 55 end cap with DN60 outlet	-	-	55		810201



	Length (mm)	Overall Width (mm)	Depth (mm)	Weight (kg/pc)	Code
	1000	118	97	6.70	406545

Image	Description	Length (mm)	Overall Width (mm)	Depth (mm)	Weight (kg/pc)	Code
	Euroline 97 combined end cap	-	-	97	0.45	38504
	Euroline 97 end cap with DN110 outlet	-	-	97	0.60	38505

ACO SELF® product overview

Euroline 100 channel body with preform DN100 knockout



Length (mm)	Overall Width (mm)	Depth (mm)	Weight (kg/pc)	Code
1000	118	139	10.20	810028

Image	Description	Length (mm)	Overall Width (mm)	Depth (mm)	Weight (kg/pc)	Code
	Euroline 139 combined end cap	-	-	139	0.80	810202
	Euroline 139 end cap with DN110 outlet	-	-	139	0.95	810203

Euroline 100 gratings

Image	Description	Length (mm)	Overall Width (mm)	Slot opening (mm)	Load capacity (kN)	Code
	Euroline S/Slinter triangle bar heelsafe grate	1000	118	6	B125	10323
	Euroline galvanized heelsafe grate	1000	118	6	A15	810102
	Euroline composite heelsafe grate	1000	118	8	B125	319250
	Euroline slotted cast iron grate	500	118	10	C250	810106
	Euroline Voronoi cast iron grate	500	118	-	C250	310319

NEW!

ACO SELF® Brickslot and accessories

The brickslot system is ideal for transitions between two different surfaces. The slotted frame consisting of stainless steel is compatible with all standard tiles, brick pavers or stone slabs and joins the two surfaces almost seamlessly. This system is superb for the drainage of façades, sophisticated surfaces and for discreet drainage solutions.

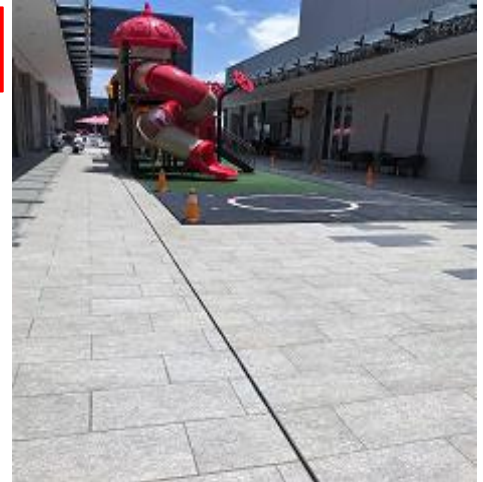

Image	Description	Length (mm)	Overall Width (mm)	Height (mm)	Slot opening (mm)	Code
	Euroline "L" shape brickslot H40 S/S304	1000	118	40	10mm	415826
	Euroline Brickslot access unit H40 S/S304	500	118	40	10mm	415827
	Euroline "L" shape brickslot H65 S/S304	1000	118	65	10mm	415834
	Euroline brickslot access unit H65 S/S304	500	118	65	10mm	415835

* Depth size 105mm available on request

Maintenance of the ACO Self® brickslot channel

Maintenance of the ACO Self® channels with Brickslot is performed via a revision element that is placed directly above the outlet.

Depending on the system there is a half-meter or 15-cm revision element available. Revision element should be opened and channel should be cleaned approx. twice a year.

Please adjust cleaning frequency to local conditions or provide a second revision element at the other end of the line to facilitate cleaning.

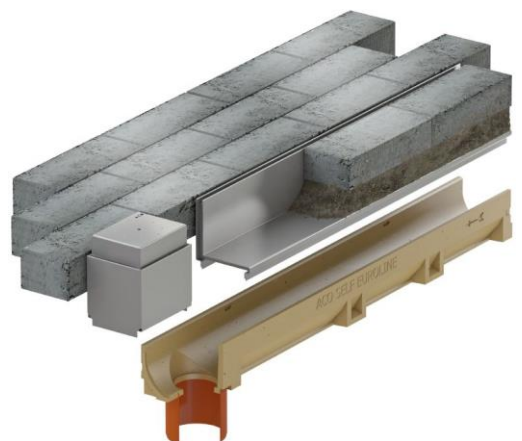



ACO Residential Drainage

Installation pictures

NEW!

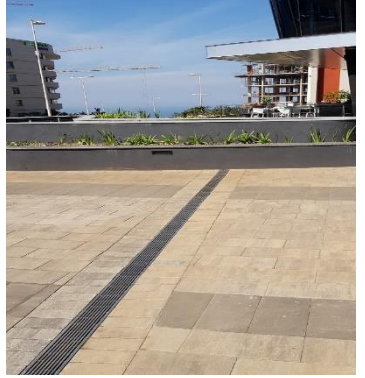
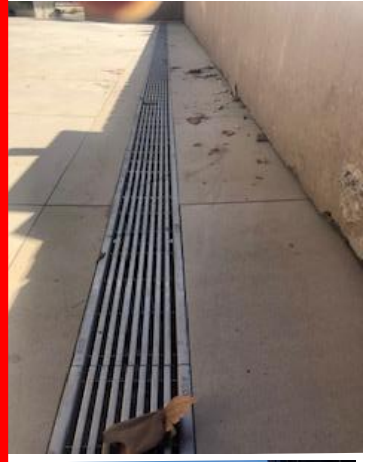

Your local sales contact

ACO DRAINAGE SYSTEMS LTD

96 Riverside Drive
Allianz Plaza Building
2nd floor
Nairobi
Kenya

Tel: +254 (0) 11 000 3001
Email: info@aco.co.ke

www.aco.co.ke
www.buildingdrainage.aco
www.hygienefirst.com



www.aco.co.ke



www.buildingdrainage.aco

WWW.

